

Material:

- \* Insulator: LCP With 30% GF.  
UL 94V-0 Color Black
- \* Square Pin: Brass
- \* Pegs: Brass , Tin plated
- \* Pick & Place Pad:  
Nylon 6T  
UL 94V-0 Color Nature

Ordering Code:

CH51 \*\* \* M 1 02 - \* \*  
① ② ③ ④ ⑤ ⑥ ⑦ ⑧

Recommended P.C. Boarded Layout

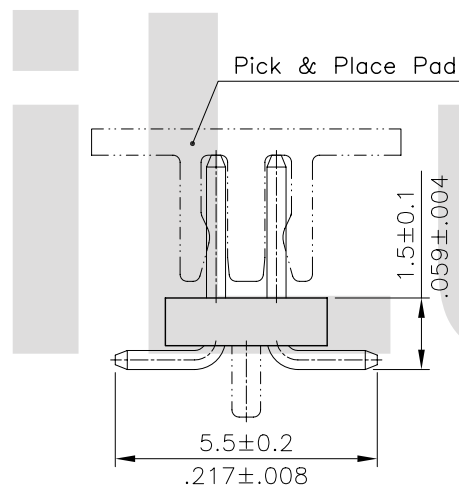
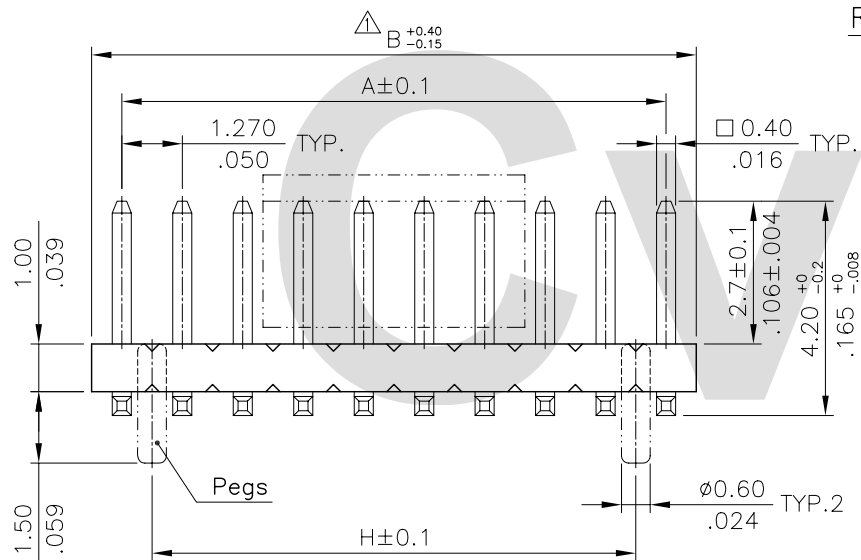

- ① Series No.
- ② No. of Contact: 06 to 100(X1=100)
- ③ Plating code:  
2=Gold Flash plated over  
1.27μm(50μ") Nickel  
3=0.38μm(15μ") Gold plated  
over 1.27μm(50μ") Nickel  
4=0.76μm(30μ") Gold plated  
over 1.27μm(50μ") Nickel
- ④ Tail & Mounting Style:  
M=Straight SMT Type
- ⑤ Insulator Material & Color:  
1=LCP , Color Black
- ⑥ Option Code:  
See Table PDF. File No. CH5102T
- ⑦ 0=Without Peg  
P=With Peg
- ⑧ 0=Without Pick & Place Pad  
(Tube packaged)  
P=With Pick & Place Pad  
(Tape & Reel packing)

DIM. A = 1.27 X No. of Spaces

DIM. B = DIM. A + 1.27

DIM. H = DIM. A - 1.27

\* Available in 6 through 100 Circuits

RoHS Compliant

4					DATE	UNIT: mm / inch	TITLE: 1.27mm(.050") DUAL ROW SURFACE BOARD MOUNT PIN HEADER	 瀚荃股份有限公司 CviLux Corporation
3					DRAWN BY: Sandy 8/27 04'	TOLERANCE UNLESS OTHERWISE SPECIFIED	MATERIAL:	
2					ENGINEER: Eisley 8/30 04'	.X ± 0.25/.010 X' ± 1'	CUSTOMER: BVI127	DRAWING NO. CH5104SB PART NO. CH51***M102-***
1	Sandy	08/27/04'	ECN04327	CHECKED BY: David	8/30 04'	.XX ± 0.15/.006 .X' ±		SCALE 6 / 1 SHEET 1 OF 1
SYM	NAME	DATE	REVISIONS	APPROVED BY: Alex	8/30 04'	.XXX ± 0.08/.003 .XX' ±		

