

Material:

- \* Insulator: LCP With 30% GF.  
UL 94V-0 Color Black
- \* Square Pin: Brass

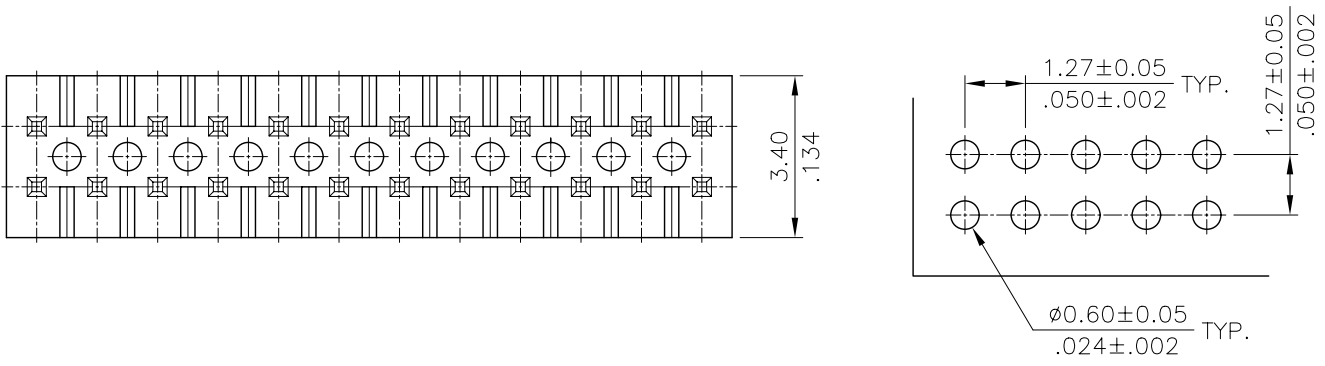

Ordering Code:

CH51 \*\* \* V 1 \*\*  
① ② ③ ④ ⑤ ⑥

- ① Series No.
- ② No. of Contact: 06 to 100  
X1=100
- ③ Plating code:  
2=Gold Flash plated over 1.27μm(50μ") Nickel  
3=0.38μm(15μ") Gold plated over 1.27μm(50μ") Nickel  
4=0.76μm(30μ") Gold plated over 1.27μm(50μ") Nickel
- ④ Tail & Mounting Style:  
V=Straight DIP Type
- ⑤ Insulator Material & Color:  
1=LCP , Color Black
- ⑥ Option Code:  
See Table PDF. File No. CH5101T

Recommended P.C. Boarded Layout

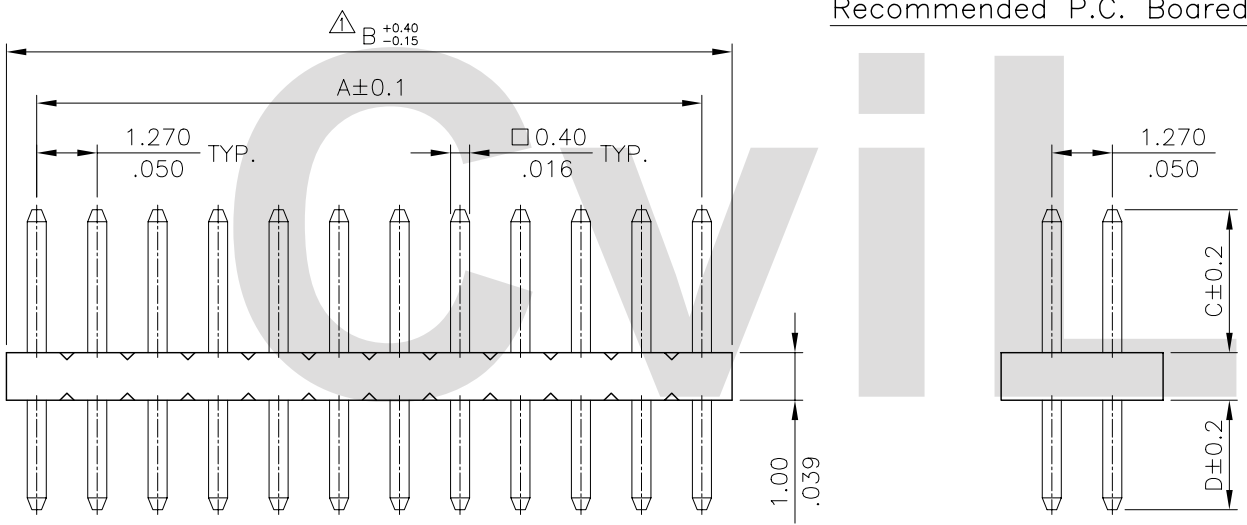

DIM. A = 1.27 X No. of Spaces  
DIM. B = DIM. A + 1.27  
\* Available in 6 through 100 Circuits

CVILUX.CORP  
2004.08.31  
ISSUED

RoHS Compliant

4				DATE	UNIT: mm / inch	TITLE: 1.27mm(.050") DUAL ROW BOARD MOUNT PIN HEADER	 瀚荃股份有限公司 CviLux Corporation
3			DRAWN BY: Sandy	8/27 04'	TOLERANCE UNLESS OTHERWISE SPECIFIED	MATERIAL:	
2			ENGINEER: Eisley	8/30 04'	.X ± 0.25/.010 X' ± 1"	FINISH:	DRAWING NO. CH5101SD PART NO. CH51***V1**
1	Sandy	08/27/04'	CHECKED BY: David	8/30 04'	.XX ± 0.15/.006 .X' ±		SCALE 6 / 1 SHEET 1 OF 1
SYM	NAME	DATE	APPROVED BY: Alex	8/30 04'	.XXX ± 0.08/.003 .XX' ±		