

Notes:

1. DIM. E = 2.5 min.
2. Pin overall length 20.0 max.
3. Material:
 - * Insulator: Nylon 6T With 30% GF. UL 94V-0 Color Black
 - * Square Pin: Brass
 - * Pick & Place Pad: Nylon 6T UL 94V-0 Color Nature

Ordering Code:

CH03 ** * M 1 ** - 0 *
 ① ② ③ ④ ⑤ ⑥ ⑦ ⑧

Recommended P.C. Board Layout

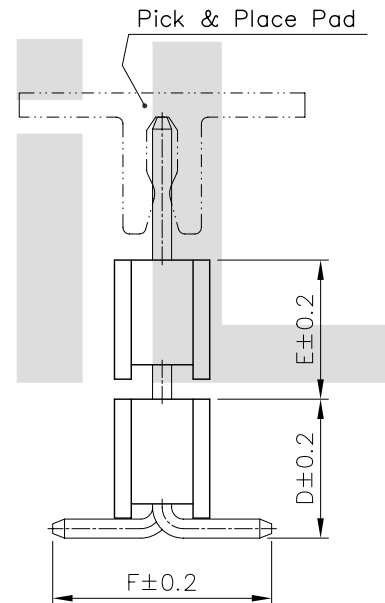
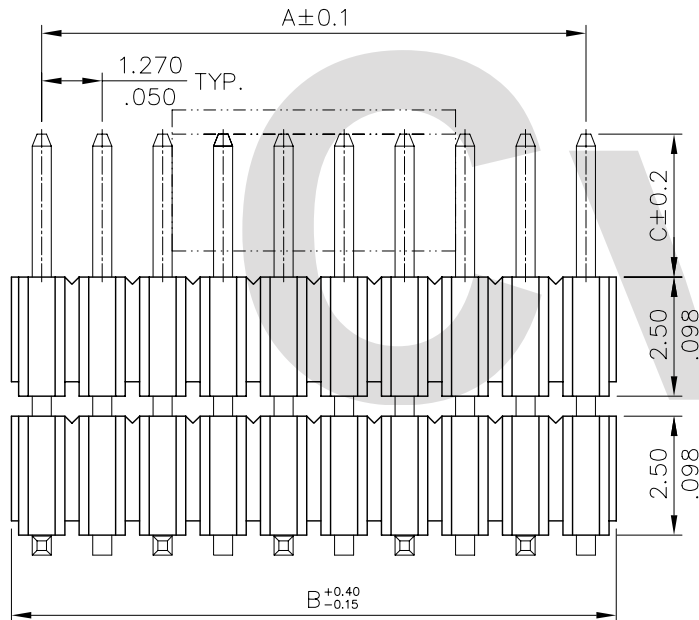

DIM. A = 1.27 X No. of Spaces

DIM. B = DIM. A + 1.27

* Available in 4 through 50 Circuits

- ① Series No.
- ② No. of Contact: 04 to 50
- ③ Plating code:
 - 2=Gold Flash plated over 1.27μm(50μ") Nickel
 - 3=0.38μm(15μ") Gold plated over 1.27μm(50μ") Nickel
 - 4=0.76μm(30μ") Gold plated over 1.27μm(50μ") Nickel
- ④ Tail & Mounting Style:
 - M=Straight SMT Type
- ⑤ Insulator Material & Color:
 - 1=Nylon 6T , Color Black
- ⑥ Option Code:
 - See Table PDF. File No. CH0302T
- ⑦ Pin Size: 0=Original design
- ⑧ 0=Without Pick & Place Pad (Tube packaged)
 P=With Pick & Place Pad (Tape & Reel packing)

RoHS Compliant

4																			
3																			
2																			
1	SUN	5/07/04'	ECN04183																
SYM	NAME	DATE	REVISIONS	APPROVED BY:	Alex	5/26 04'													
				DRAWN BY:	Sun	5/19 04'	UNIT: mm / inch		TITLE: 1.27mm(.050") SINGLE ROW DUAL BODY SURFACE BOARD MOUNT PIN HEADER		 瀚荃股份有限公司 CviLux Corporation								
				ENGINEER:	Eisley	5/21 04'	TOLERANCE UNLESS OTHERWISE SPECIFIED		MATERIAL:										
				CHECKED BY:	David	5/26 04'	.X ± 0.25/.010	X' ± 1"	FINISH:										
				APPROVED BY:	Alex	5/26 04'	.XX ± 0.15/.006	.X' ±	DRAWING NO. CH0302SC										
							.XXX ± 0.08/.003	.XX' ±	SCALE 6 / 1		SHEET 1 OF 1								

