



SPECIFICATION FOR APPROVAL

Part name: Din-Rail Terminal Block

Part No.: RTB425-00-01-9

Cust. P/N:

Date: 2010-02-08

Seller Confirmation

Written by	Zhujiwei
Checked by	SJ.Fu
Approved by	Bill

Customer Confirmation

Project Audit	
Structure Audit	
Security Certification	
Quality Approval	

Supplier : Hangzhou antron electronics Co., Ltd.

Address : No.639 , Deng yun Road , Hangzhou China

Tel : 0571-89902210

Fax : 0571-89908128

Postcode: 310011

E-mail : anqiao@263.net

Customer:

Customer P/N:

Seller: Hangzhou antron electronics Co., Ltd.

Part No: RTB425-00-01-9

Revision for RTB425-00-01-9

Item No	Edition	Part Revised	Date Revised
1	A	put in file	2010-02-08
2			
3			
4			
5			
6			
7			
8			
9			

1.TYPE: RTB425-00-01-9



2.DRAWING&SIZES

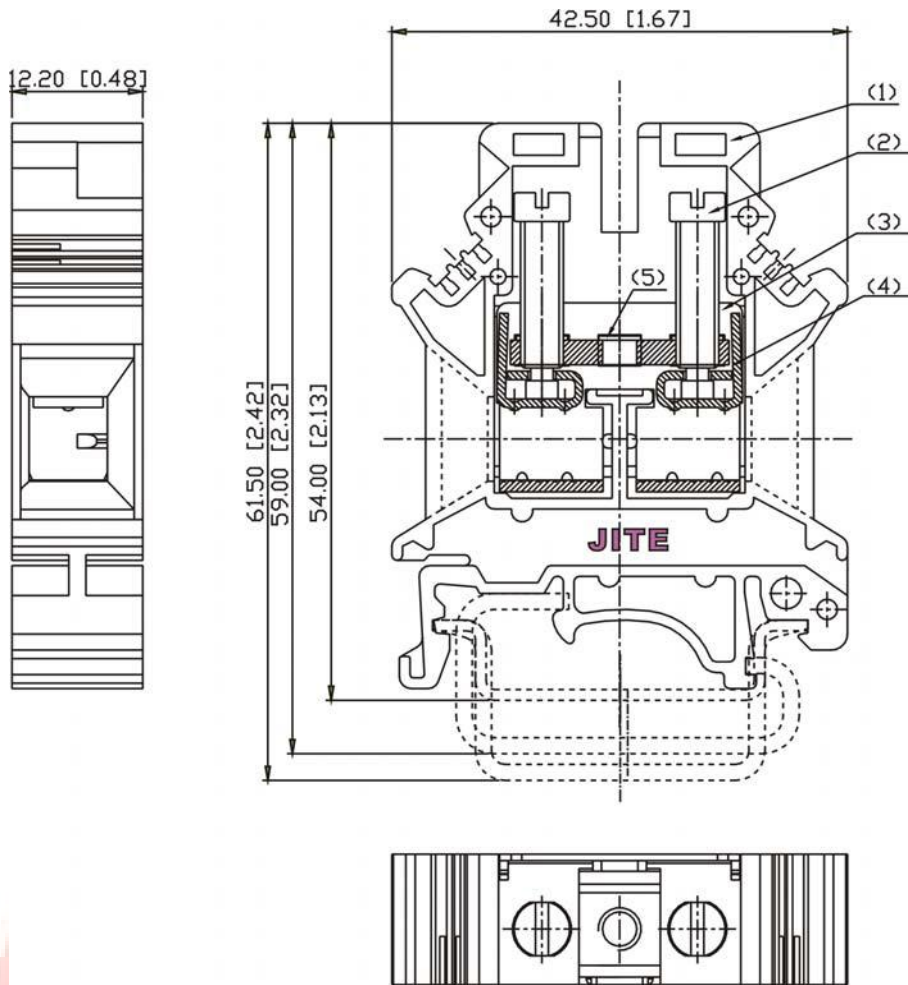

OVERALL SIZES

TOLERANCE:

> 120	±0.80
> 30 ~ 120	±0.50
> 6 ~ 30	±0.40
0 ~ 6	±0.25

3.BOM TABLE

ITEM.	PART NAME	MATERIAL	SURFACE OF CONTACT	QUANTIT Y(PCS)
(1)	Body	PA66 UL94		1

		V-0		
(2)	Screw	BRASS H59	Nickel Plated 5um	2
(3)	Block	BRASS H62	Pure mist Tin Plated 5um	1
(4)	Block plate	BRASS H62	Pure mist Tin Plated 5um	2
(5)	Contact	BRASS H59	Pure mist Tin Plated 5um	1

4. TECHNICAL DATA:

WIRE RANGE:	4~22AWG
MAX. TORQUE:	10.6 lbf.in
ELECTRICAL RATING:	600V, 85A.
DIELECTRIC WITHSTAND:	AC3000V, 1 minute
BREAKDOWN VOLTAGE:	8000V (1.2/50μs)
CROSS SECTION:	25mm²
STRIPPING LENGTH:	11mm

5. WORKING CONDITION:

OPERATING TEMPERATURE:	-40℃~+105℃
ALTITUDE:	Less than 2000m 40Kpa~80KPa
RELATIVE HUMIDITY:	5%~95%
POLLUTION DEGREE:	III

6. APPLICABLE STANDARDS

IEC 60947-1:2001 IEC 60947-7-1:2002 UL 1059:2001

7.ACCESSORIES

MOUNTING RAIL:	JNS35:7.5/JNS35:15/JNS32
COVER:	A048-9
SEPARATING PLATE:	A142-9
MARKING STRIP:	A055-10-5
Fixed bridge:	A133-10-22
Separating Disk:	A048-9
Rail stator:	GD001 or A047-9

8.PROCEDURE

Wires can be connected with this type of terminal blocks by a manual or automatic screwdriver.

9. PACKAGE

Tightly Sealed